



BATHROOMS

01



## GO PLUS DESIGNS WITH STEEL

Stainless steel is an alloy made by combining iron and carbon that becomes resistant to corrosion from external agents and rust, thanks to passivation, that is a protecting film that steel forms when exposed to air. There are many types of stainless steel, which are commonly identified with AISI (the acronym of the American Iron and Steel Institute) which specifies the kind of steel with a three-digit number (AISI 304, AISI 316, AISI 430, etc.) and then it may be integrated with a letter specifying a particular component in the structure of the alloy. CEA has decided to work with AISI 316L for all its taps, where L stands for low carbon, which prevents impurities from penetrating the alloy structure. AISI 316L is very resistant to corrosion, therefore ideal at seaside and spa areas and wherever pollution is high. Steel is an inert material (it does not send out substances toxic to mankind and the environment when exposed to air or water) which, unlike brass, does not need any further treatment (such as galvanic treatment or varnishing), thus keeping its purity and being extremely hygienic. CEA has chosen steel in compliance with the principles of sustainability and respect of the environment and its resources. Stainless steel is universally recognised as an eco-friendly material that needs far lower temperatures to be produced in comparison to other metals. CEA adopts cold working methods for stainless steel, with the exclusive help of highly precise numerical control machines. No hot melt treatment is used at CEA, which avoids the resulting thermal overheating. The long-term life of the products confirms the eco-friendliness of stainless steel and its mechanical resistance determines the durability of steel and its products. Not only is steel 100% recyclable, but also almost eternal.

To keep its qualities, you just need to clean steel with a soft cloth or sponge and a regular cleaner mixed with some water, then rinse it and wipe it dry. Any possible water-caused limescale or iron deposit can be easily cleaned with specific products for stainless steel. These are easy to find on the market. Bleach or hydrochloric acid may damage the natural protecting film of stainless steel. Make sure you never use metal scouring pads which may leave iron residuals leading to rust on the surface.

Please note that in case of scratches, steel can be restored both by polishing and satinising mechanical treatment.



## GO PLUS PROYECTA CON ACERO

*El acero inoxidable es una aleación de hierro y carbono que, por pasivación, es decir a través de una película protectora que se forma en contacto con el aire, se hace resistente a la corrosión y la acción por agentes externos, sobre todo a la oxidación. Se venden distintos tipos de acero, comúnmente identificados con la sigla AISI (acrónimo inglés del instituto norteamericano para el hierro y el acero - American Iron and Steel Institute) que identifica el tipo con tres cifras (AISI 304, AISI 316, AISI 430, etc.) y la posible letra que muestra la presencia de un particular componente en la estructura de la aleación. CEA ha decidido trabajar con acero AISI 316L para todos sus grifos. L está para low carbon, bajo en carbono, que es lo que impide la penetración de impurezas. AISI 316L es un material inerte (no emite sustancias tóxicas para el medio ambiente o el hombre en contacto con el aire o el agua) que, a diferencia del latón, no necesita tratamientos adicionales (galvanización o barnizado), manteniéndose así puro y extremadamente higiénico. CEA ha elegido el acero para respetar los principios de sostenibilidad y protección medioambiental. El acero inoxidable es un material ecológico que se produce con temperaturas más bajas que otros metales. CEA trabaja el acero en frío con máquinas CNC muy precisas, sin termofusión ni sobrecalentamiento. Además de ser 100% reciclable, el acero es prácticamente eterno, gracias a su alta resistencia mecánica.*

*Para conservar las características del acero, es suficiente limpiarlo con una bayeta o una esponja suave y un normal limpiador en crema diluido en agua, aclararlo y luego secarlo. Eventuales depósitos de cal o hierro del agua se eliminan fácilmente con productos específicos para la limpieza del acero inoxidable. Éstos se hallan fácilmente en los supermercados. Detergentes a base de lejía o ácido clorhídrico pueden dañar la película protectora del acero inoxidable. Otra advertencia importante es no utilizar nunca estropajos metálicos que podrían dejar residuos de hierro sobre la superficie de los productos y causar manchas de oxidación. En caso de que la superficie esté rayada, recuérdese que el acero se puede restablecer por tratamiento mecánico en ambos acabados, satinado y pulido.*



# GO PLUS DESIGNS TECHNOLOGY

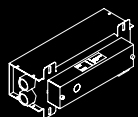

## BOX

The BOX installation system is used for wallmounted taps and includes a built-in empty box where the supply hoses of the hot and cold water are located.

The BOX system also allows all working parts of the tap to be located at the front of the wall, which assists with any future service requirements.

Sistema mural de instalación del grifo con una caja vacía donde se ponen los flexos. BOX no incluye cartuchos para la mezcla de agua que vienen con la parte exterior del grifo.

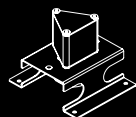

## INC

The INC is a fixing bracket used to anchor shower and bathtub fittings, including water spouts, hand showers and shower heads on to the walls, ceilings and floors.

Elemento de fijación para sujetar las columnas ducha/bañera, los caños, las teleduchas, los rociadores sobre paredes /techos en escayola y suelos.

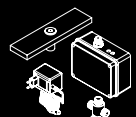

## IRS (INFRARED SENSOR)

The IRS is a presence detection system using infrared technology and is powered with 9 volts or standard electric current. The IRS can be combined with wall, deck or ceiling mounted outlets and can also be used with freestanding taps. The sensor can be placed vertically on the wall or horizontally on the countertop. The sensor is activated when a hand or other body part comes close to the sensor location, which then in turn activates the tap

Sistema de detección de presencia por infrarrojo con batería de 9 voltios o por corriente eléctrica, combinable con caños de repisa, murales, de techo y a suelo. El sensor se puede colocar sobre la repisa o en frente de la misma y seacciona respectivamente acercando la mano al sensor o el cuerpo al lavabo.



## PTR (PLUMBING TELESCOPIC REGULATOR)

The PTR is a universal built-in part that allows adjustability in its depth into the wall and is also interchangeable with a number of collections. The PTR is a great advantage on the building site, it avoids the use of extensions and cutting tools to adapt the built-in part to the taps and also reduces installation time. The PTR is a patent by GO PLUS.

Parte empotrada universal que permite regular la profundidad en el muro e intercambiar las colecciones a las que se combina. PTR ofrece una gran ventaja durante las obras, evitando el uso de alargadores y cortadoras para adaptar la parte empotrada al grifo y reduciendo los tiempos de trabajo. PTR es una patente GO PLUS.

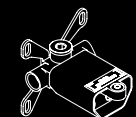

## PWF (PIPE WATER FITTING)

The PWF is a universal fitting that enables a quick and easy connection of the tap to the wall. With PWF system, the mixing parts of the tap, including the cartridge, are located at the front of the wall. The PWF is fully adjustable and this removes any problems of fitting the tap to un-even or un-level walls. It also makes any future service requirements very easy. The PWF is a patent by GO PLUS.

Sistema de conexión universal para la instalación hidráulica. Permite una colocación rápida del grifo a la pared y una instalación fácil y veloz. Con PWF la mezcla de agua es exterior a la pared y se evitan problemas relacionados con la instalación mural del grifo. PWF es una patente GO PLUS.

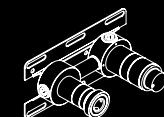

## UCS (UNIVERSAL CARTRIDGE SYSTEM)

The UCS is a built-in part used across the CEA tap family, as it is interchangeable between different CEA collections. The UCS can be used with the CARTESIO, INNOVO, MILO360 and GASTONE collections. The UCS is a patent by GO PLUS.

Cuerpo de encastrar universal para familia de productos. Es común a tres diferentes colecciones CEA. Ventajas: con el mismo cuerpo de encastrar, es posible combinar las partes externas de las colecciones CARTESIO, INNOVO, MILO360, GASTONE. UCS es una patente de GO PLUS.

# GO PLUS PROYECTA TECNOLOGÍA



## ICONS ICONOS



Articles that need (BOX / INC / PWF / PTR / UCS) built-in parts as specified in the product chart  
Artículos que necesitan partes empotradas (BOX / INC / PWF / PTR / UCS) como especificado en la tabla de productos



Articles marked with this symbol are water saving (from 5 lt/min to 10 l/min)  
Los artículos marcados con este símbolo, son de ahorro energético (de 5 lt/min a 10 lt/min)



Articles marked with this symbol are high water flow ( $\geq 30$  l/min)  
Los artículos marcados con este símbolo, son de alto caudal ( $\geq 30$  lt/min)



Articles marked with this symbol are suitable for both wash-basin and bathtub  
Los artículos marcados con este símbolo se pueden utilizar tanto para lavabo como para llenado de bañera



Articles with wall fixing bracket. Fixing bracket helps product installation  
Artículos con elemento de fijación a pared. El elemento de fijación simplifica la instalación del producto



Articles with optional auxiliary fixing bracket for mounting on plasterboard and fiber plasterboard false ceilings and walls  
Artículos con elemento opcional de fijación auxiliar para montaje en paredes y techos de placa de yeso y placa de fibra-yeso



Articles with optional auxiliary fixing bracket (FIX01) with regulation in depth to be used with equipped fixing brackets and/or INC03 for plasterboard and fiber plasterboard ceilings and walls  
Artículos con elemento opcional de fijación auxiliar (FIX01) con regulación en profundidad que se utiliza con elemento opcional de fijación en dotación y/o INC03 para paredes y techos de placa de yeso y placa de fibra-yeso



SET15: Articles with alternative auxiliary connection for shower heads that abut against the ceiling  
SET15: Artículos con elemento alternativo de conexión auxiliar para la instalación de rociadores a techo



Vertical assembly is also possible  
Artículos con instalación también en vertical





### GIO 40

Wall mounted single lever mixer with 1/2" gas connection Wandmischer 1/2"  
 Mezclador monomando mural con conexiones de 1/2"  
 481 Aprox.

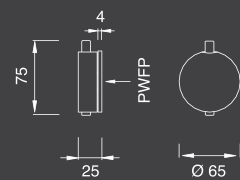

### NEU 23 + GIO 40

Free-standing spout for washbasin H. 1120 mm  
 Caño lavabo a suelo H. 1120 mm  
 656 Aprox

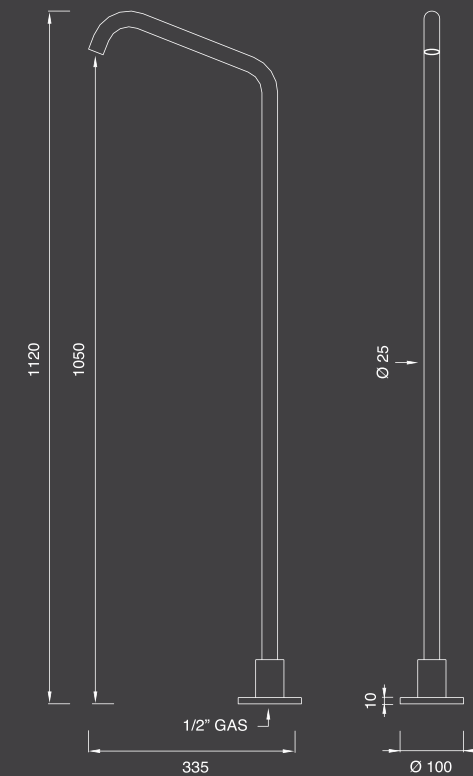



**GIO 13**

Wall mounted set of 2 individual taps with spout L. 120 mm  
 Grupo grifería con dos llaves individuales a muro con caño L. 120 mm  
 450 Aprox.

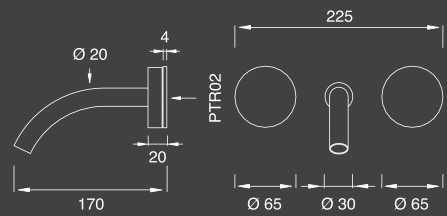

**GIO 22**

Deck mounted hydroprogressive mixer with spout H. 255 mm  
 Mezclador hidroprogresivo monomando con caño H. 255 mm  
 775 Aprox.

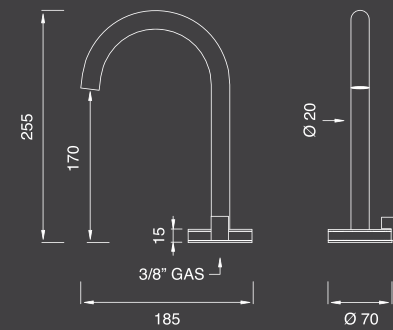



### GIO 16

Three-hole mixer with swivelling spout H. 245 mm  
 Grifería con 3 orificios con caño giratorio H. 245 mm  
 1.187 Aprox.

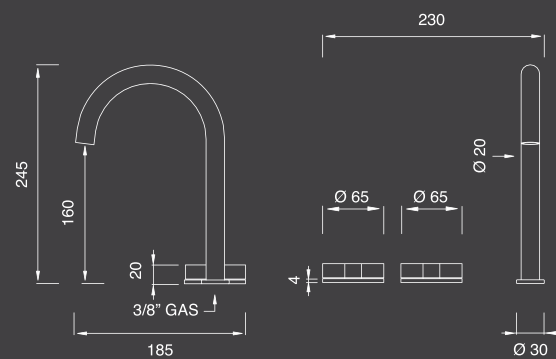

### GIO 25W

Set of 2 hydroprogressive mixers for bath/shower with hand shower  
 Grupo 2 mezcladores hidroprogresivos para bañera/ducha con teleducha  
 637 Aprox

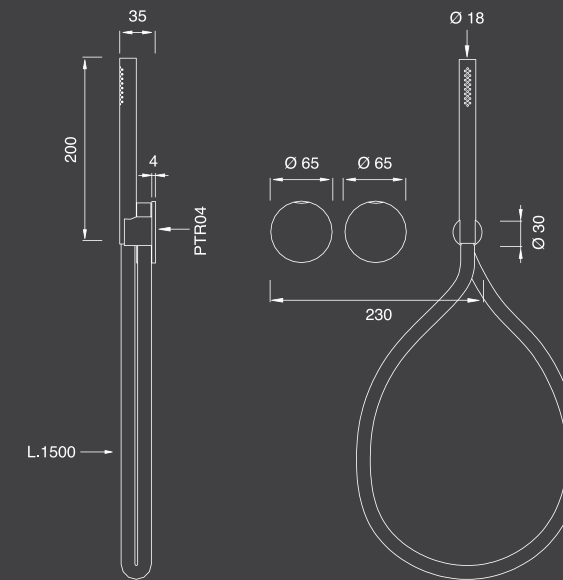



### NEU 26 + GIO 25W

Adjustable water saving shower head (5 lt/min) P. (185 mm)  
Rociador orientable con ahorro de agua (5 lt/min) P. (185 mm)  
337 Aprox.

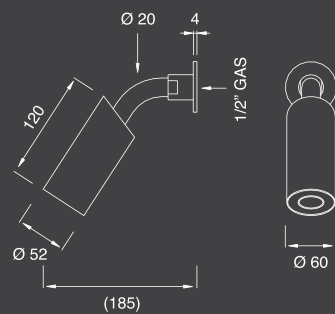

### FRE 15+ GIO 28

Rim mounted set of 2 hydroprogressive mixers with hand shower  
Grupo 2 mezcladores hidroprogresivos para borde bañera con teleducha  
781 Aprox.

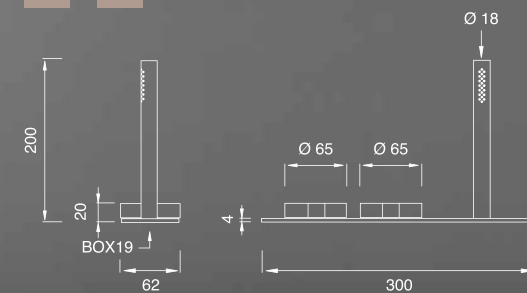



### FRE 15

Waterfall spout L. 115 mm with removable aerator, without built-in part  
Caño cascada P. 115 mm con aireador movable, sin cuerpo empotrado  
806 Aprox.

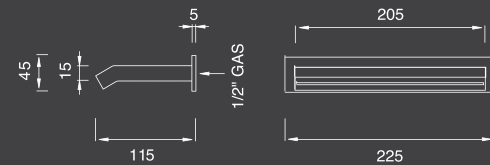

GIO 05 + GIO 04 + GIO 02 + GIO 06 + POS 06

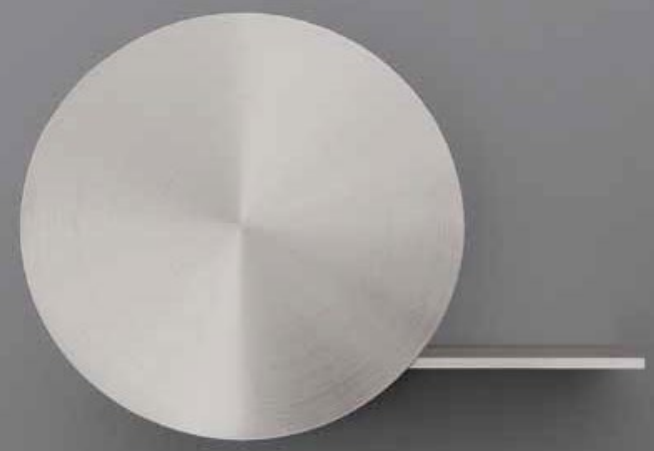

**GIO 05**

Shelf L. 150 mm  
Repisa L. 150 mm  
300 Aprox.

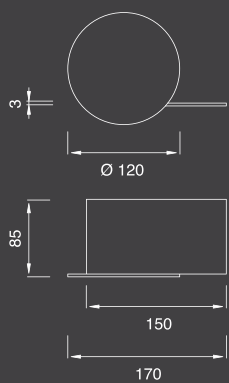

**GIO 06**

Toilet-roll holder  $\varnothing$  120 mm  
Portarollo  $\varnothing$  120 mm  
175 Aprox.

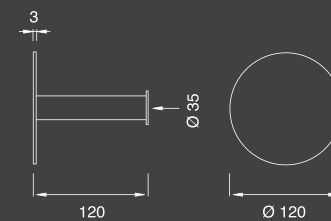



### ZIQ 10K

Three-hole mixer with swivelling spout H. 245 mm  
Grifería con 3 orificios con caño giratorio H. 245 mm  
1.218 Aprox

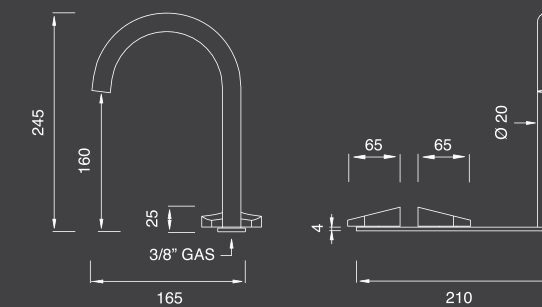



### ZIQ 02K

Wall mounted set of 2 individual taps with spout L. 170 mm  
 Grupo grifería con dos llaves individuales a muro con caño L. 170 mm  
 543 Aprox.

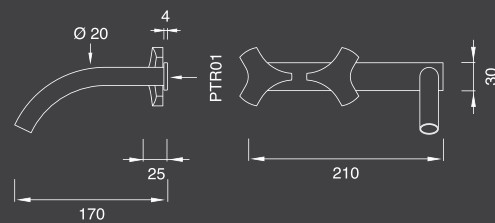

### ZIQ 08

Wall mounted set of 2 individual taps with spout L. 170 mm  
 Grupo grifería con dos llaves individuales a muro con caño L. 170 mm  
 531 Aprox.

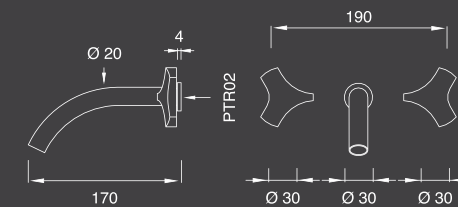





FRE 52 + ZIQ 16 + ZIQ 17



**ZIQ 39**

Deck mounted hydroprogressive mixer H. 155 mm  
Mezclador hidroprogresivo monomando H. 155 mm  
462 Aprox

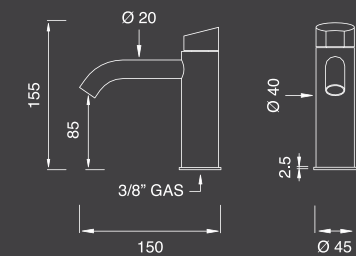

2 ZIQ 18 + MIL 90W + ZIQ 53



**ZIQ 44W**

Set of 2 hydroprogressive mixers for bathtub with spout and hand shower  
 Grupo 2 mezcladores hidroprogresivos para bañera con cãno y teleducha  
 981 Aprox.

**+** **FIX**

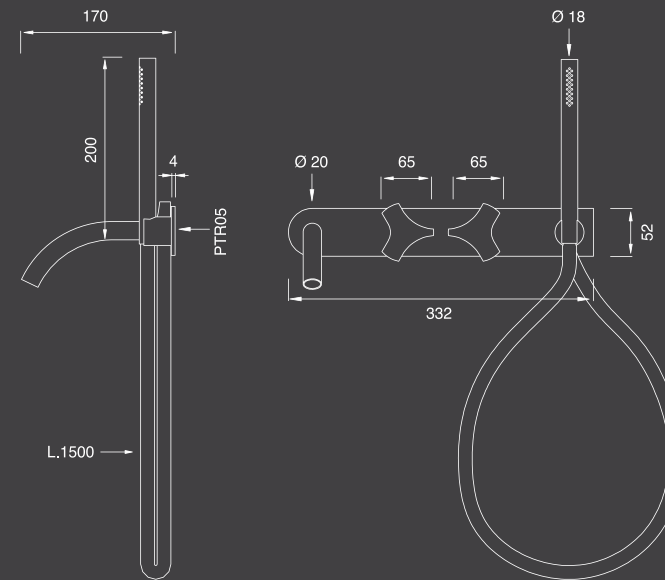



ZIQ 68 + POS 05 + ZIQ 66 + DOS 01 + ZIQ 61



### ZIQ 60

Towel rail L. 400 mm  
Toallero L. 400 mm  
225 Aprox

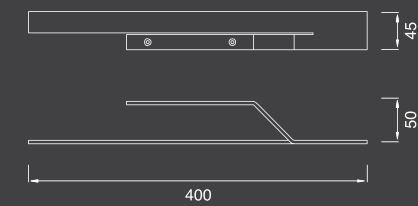



**ZIQ 66**

Shelf L. 240 mm  
Repisa L. 240 mm  
193 Aprox.

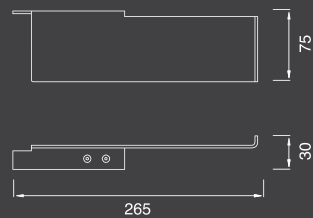

**BAR 30**  
Deck mounted hydroprogressive mixer H. 145 mm  
Mezclador hidroprogresivo monomando H. 145 mm  
875 Aprox.

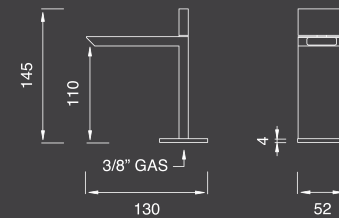



**BAR 31**

Deck mounted hydroprogressive mixer H. 95 mm  
 Mezclador hidroprogresivo monomando H. 95 mm  
 662 Aprox.

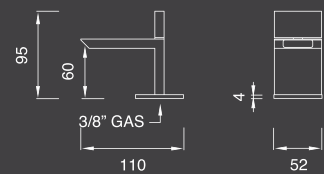

**BAR 29**

Three-hole mixer with spout H. 115 mm  
 Grifería con 3 orificios con caño H. 115 mm  
 1.168 Aprox.

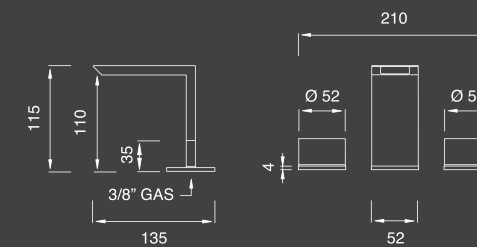



### BAR 17

Wall mounted hydroprogressive mixer with spout L. 105 mm  
Mezclador hidroprogresivo mural con caño L. 105 mm  
562 Aprox.

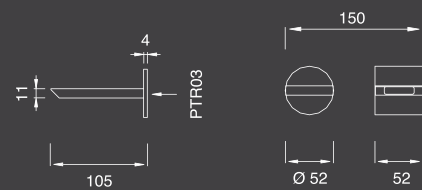

### BAR 16

Wall mounted hydroprogressive mixer with spout L. 155 mm, horizontally assembled  
Mezclador hidroprogresivo mural con caño L. 155 mm, montaje horizontal  
593 Aprox.

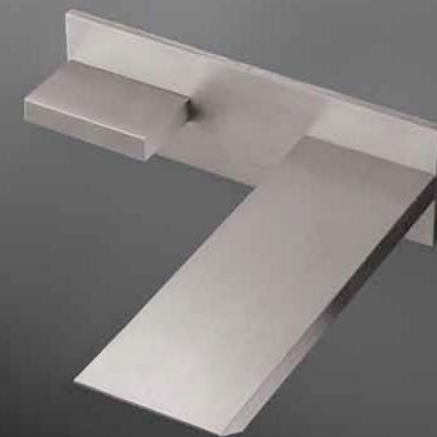
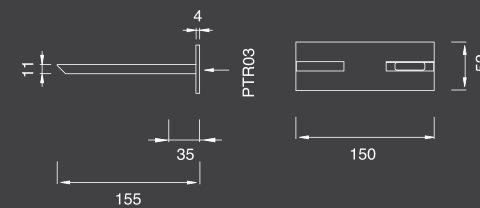



### 2 BAR 50 + SWI 07W

Wall mounted hydroprogressive mixer with 1/2" gas connection  
 Mezclador hidroprogresivo mural con conexiones de 1/2" gas  
 162 Aprox.

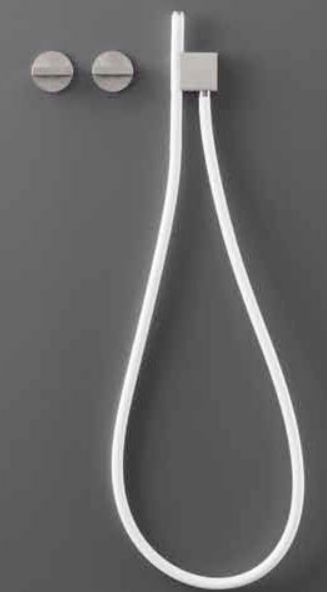
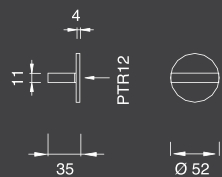

### 2 BAR 50 + SWI 07W + ZIQ 52

Hand shower in silicone rubber with bracket/water connection  
 Teleducha en goma de silicona con soporte/toma de agua  
 281 Aprox.

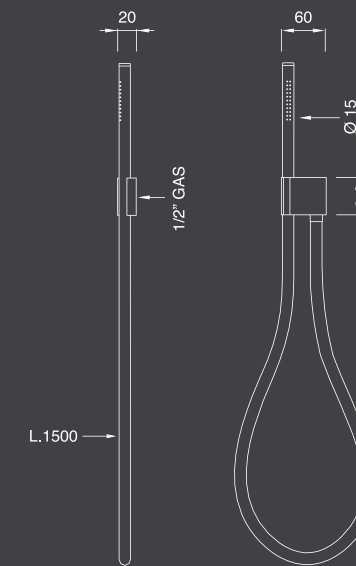

### ZIQ 52

Adjustable Delrin® shower head with rain jet P. (130 mm)  
Rociador orientable en Delrin® con efecto lluvia P. (130 mm)  
700 Aprox

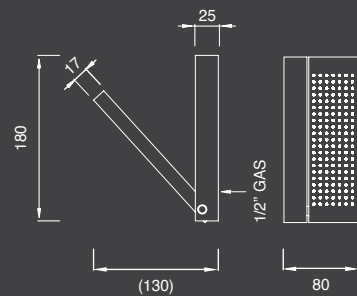

### BAR 41

Shower set H. 1200 mm with Delrin® adjustable shower head and hand shower  
Grupo ducha H. 1200 mm con rociador orientable en Delrin® y teleducha  
1.750 Aprox.

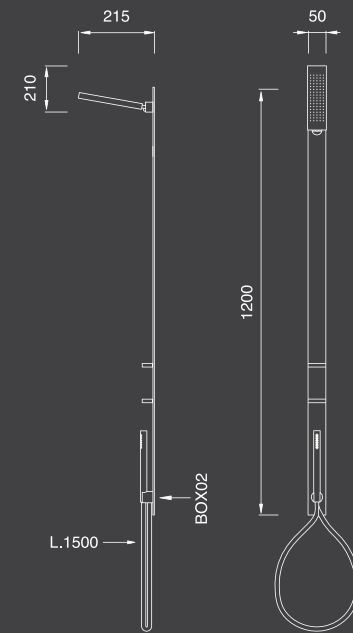



### BAR 37

Rim mounted set of 2 hydroprogressive mixers with spout and hand shower  
Grupo 2 mezcladores hidroprogresivos para borde bañera con cño y teleducha  
1.368 Aprox.

+ SET

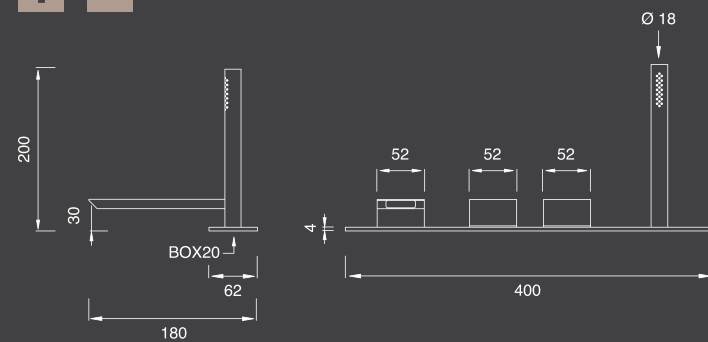

### NEU 04

Dual lever wall mounted mixer with 1/2" gas connection  
Mezclador bimando mural con conexiones de 1/2" gas  
662 Aprox

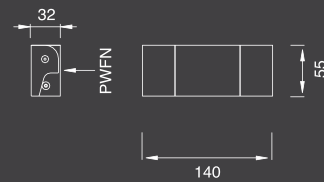

### BAR 55

Deck mounted spout H. 35 mm  
Caño de repisa H. 35 mm  
750 Aprox

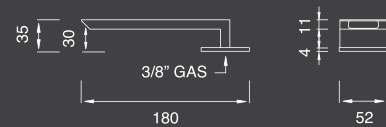

### NEU 01

Dual lever wall mounted mixer with spout L. 235 mm  
Mezclador bimando mural con caño L. 235 mm  
800 Aprox.

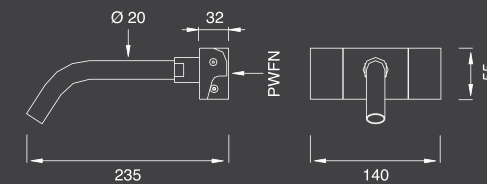





### FRE 49

Waterfall spout L. 115 mm with removable aerator, without built-in part  
 Caño cascada P. 115 mm con aireador movable, sin cuerpo empotrado  
 750 Aprox.

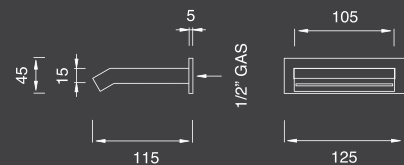

### NEU 17

Dual lever deck mounted mixer with 3/8" gas connection  
 Mezclador bimando de repisa con conexiones 3/8" gas  
 693 Aprox.

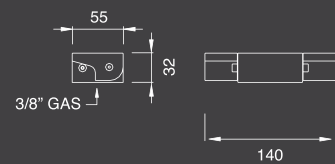

### NEU 14

Dual lever deck mounted mixer with adjustable spout L. 130 mm  
 Mezclador bimando con caño orientable L. 130 mm  
 793 Aprox.

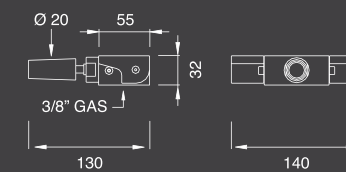



### MIL 73 + NEU 37

Ceiling mounted spout H. max. 1650 mm  
 Caño de techo H. max. 1650 mm  
 312 Aprox.

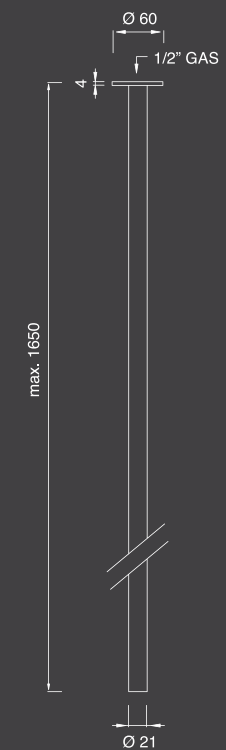

### NEU 15

Dual lever wall mounted mixer with adjustable spout L. 105 mm  
 Mezclador bimando mural con caño orientable L. 105 mm  
 793 Aprox

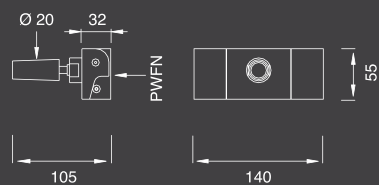



### NEU 05

Deck mounted swivelling spout H. 255 mm  
 Caño giratorio de repisa H. 255 mm  
 300 Aprox.

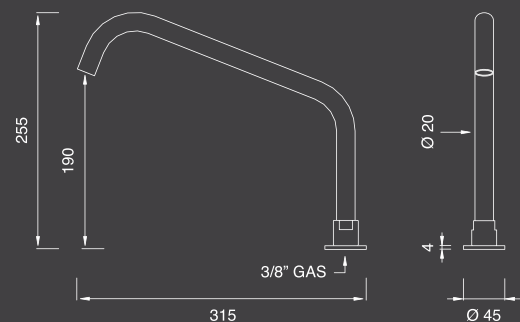

### NEU 52

Deck mounted single lever mixer with 3/8" gas connection  
 Mezclador monomando de repisa con conexiones de 3/8" gas  
 481 Aprox.



### NEU 48

Wall mounted single lever mixer with 1/2" gas connection  
 Mezclador monomando mural con conexiones 1/2" gas  
 375 Aprox.



### NEU 34

Wall mounted adjustable spout L. 75 mm  
 Caño orientable mural L. 75 mm  
 218 Aprox.

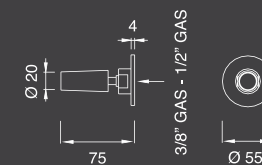



### NEU 50

Deck mounted mixer with adjustable spout H. 105 mm  
Mezclador monomando con caño orientable H. 105 mm  
668 Aprox.

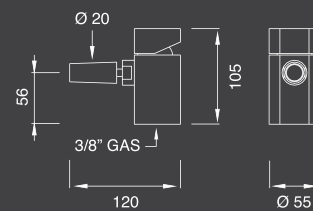



### NEU 03

Dual lever wall mounted mixer with hand shower connection, 1/2" gas connection  
 Mezclador bimando mural con toma de agua para teleducha, conexiones de 1/2" gas  
 718 Aprox.

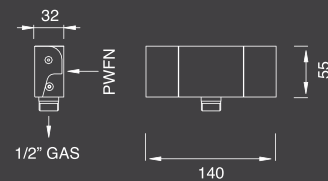

### NEU 46W

Water saving shower head (5 lt/min) with wall brackets  
 Rociador con ahorro de agua (5 lt/min) con soportes murales  
 606 Aprox.

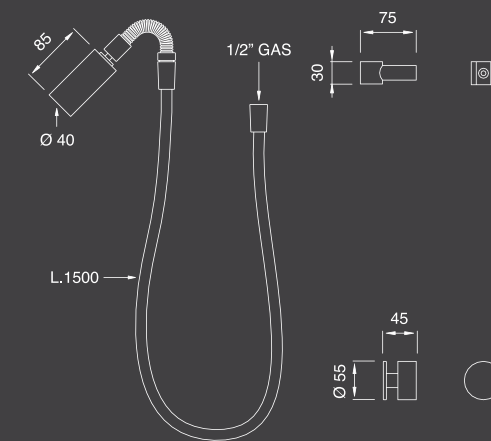



Wall mounted coaxial thermostatic mixer with shut-off valve, 1/2" gas connection  
Mezclador coaxial termostático mural con llave de paso, conexiones de 1/2" gas  
900 Aprox

### NEU 33

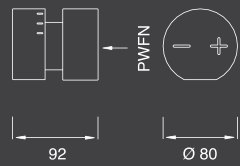

NEU 38 + FRE 18W + FRE 19 + NEU 33 + FRE 41

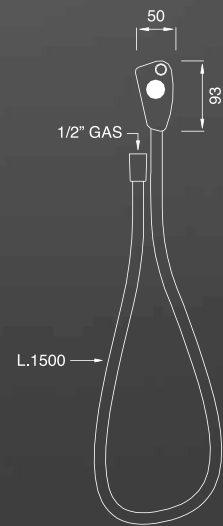

**NEU 22 + NEU 04 + NEU 03 + NEU 32G**

Delrin® hand shower with bracket, without water connection  
Teleducha en Delrin® con soporte, sin toma de agua  
218 Aprox.



**NEU 08 + NEU12 + DOS 03 + NEU 10 + NEU 83 + NEU 43**



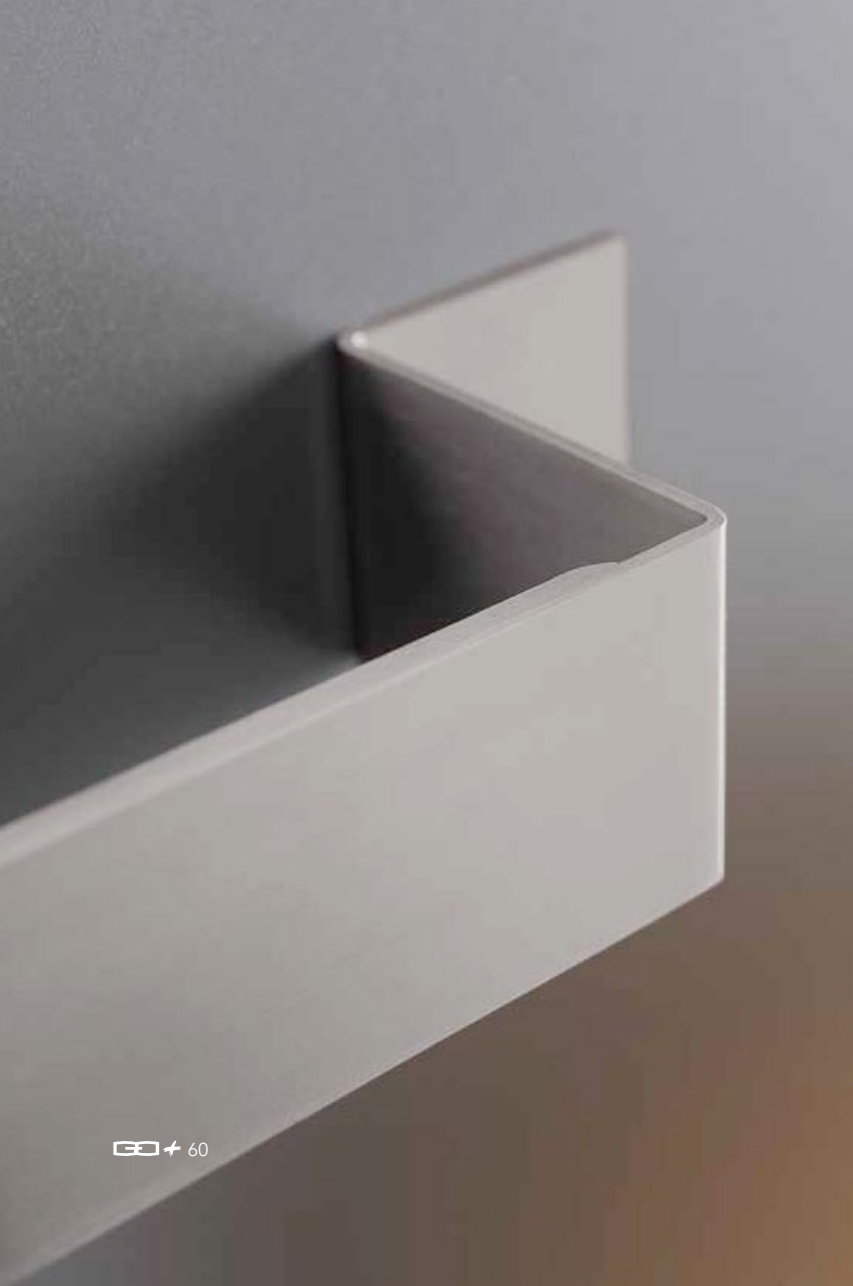

### NEU 06 + NEU 07 + NEU 08

Towel rail L. 450 mm  
Toallero L. 450 mm  
187 Aprox.



### NEU 12

Multipurpose shelf  
Repisa de almacenamiento  
187 Aprox.

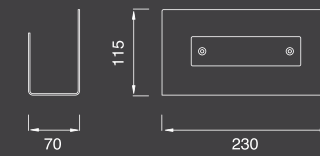

**CIR 05**  
 Dual lever wall mounted mixer with 1/2" gas connection  
 Mezclador bimando mural con conexiones de 1/2" gas  
 568 Aprox

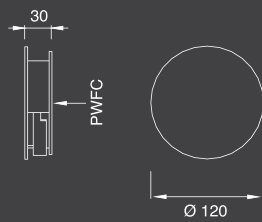

**FRE 57 +CIR 05**  
 Free-standing spout for washbasin H. 1100 mm  
 Caño lavabo a suelo H. 1100 mm  
 593 Aprox.

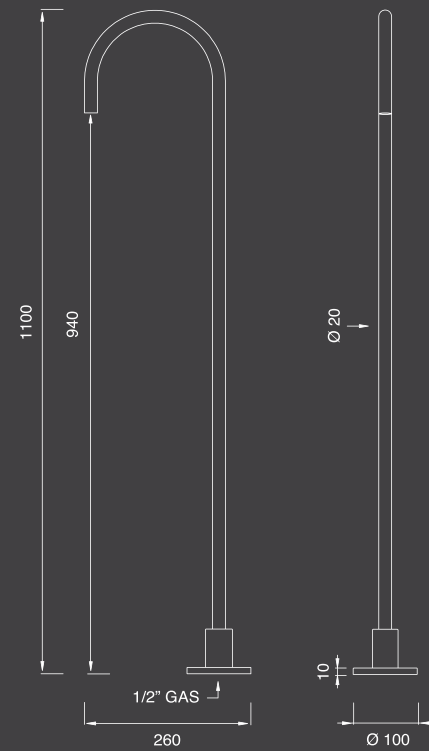

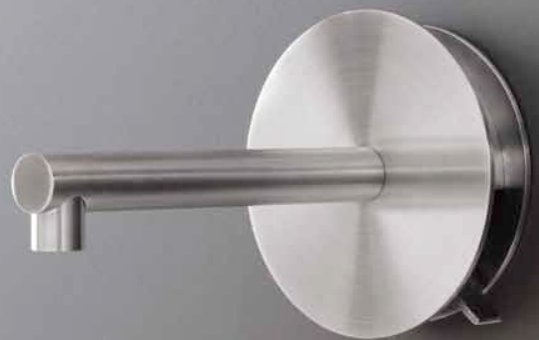

### CIR 01

Dual lever wall mounted mixer with spout L. 190 mm  
 Mezclador bimando mural con caño L. 190 mm  
 687 Aprox.

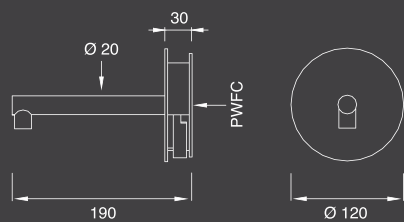

### CIR 08W + FRE 60

Dual lever wall mounted mixer with Delrin® hand shower  
 Mezclador bimando mural con teleducha en Delrin®  
 843 Aprox.

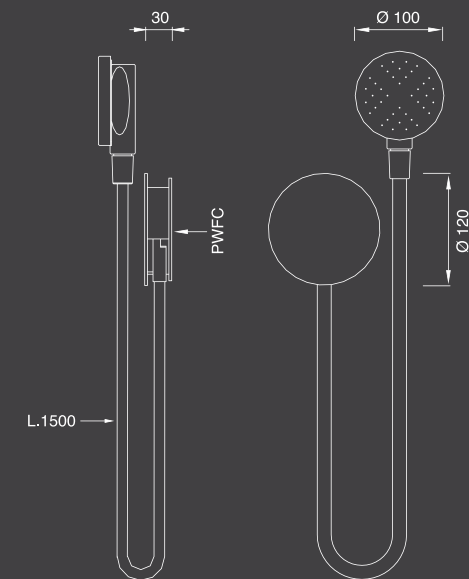



**FRE 41**

Adjustable Delrin® shower head with rain jet P. 150 mm  
Rociador orientable en Delrin® con chorro lluvia P. 150 mm  
387 Aprox.

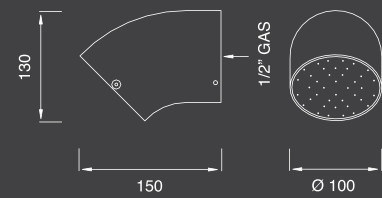





**CIR 05 + CIR 04W + FRE 41**

Dual lever wall mounted mixer with hand shower  
 Mezclador bimando mural con teleducha  
 918 Aprox.

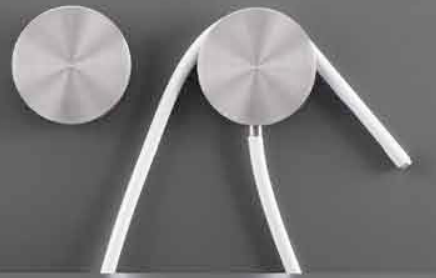
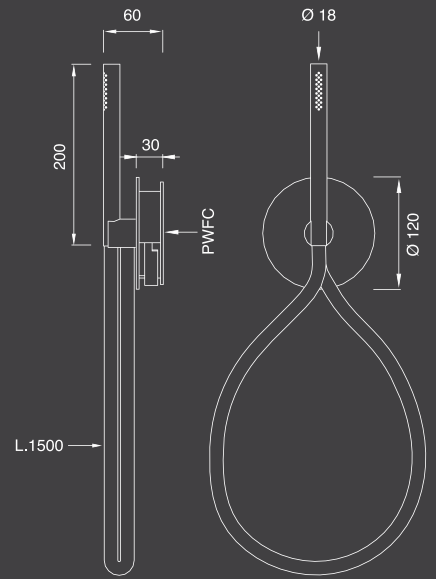

**FRE 10 + CIR 05 + CIR 07W**

Dual lever wall mounted mixer with hand shower in silicone rubber  
 Mezclador bimando mural con teleducha en goma de silicona  
 700 Aprox.

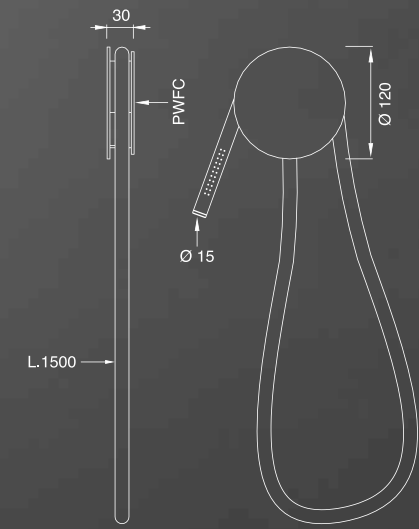



**SWI 01**

Dual lever wall mounted mixer with spout L. 180 mm  
 Mezclador bimando mural con caño L. 180 mm  
 1.193 Aprox

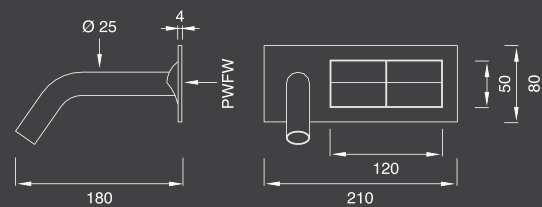

**SWI 11+ FRE 39**

Waterfall spout L. max. 100 mm  
 Caño cascada P. max. 100 mm  
 575 Aprox.

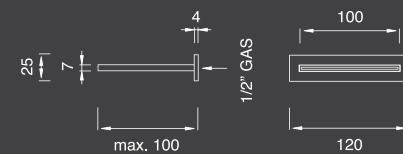

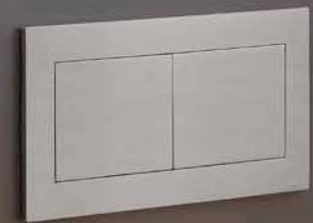

### SWI 06 + FLX 03W

Deck mounted swivelling spout H. 190 mm  
Caño giratorio de repisa H. 190 mm  
300 Aprox.

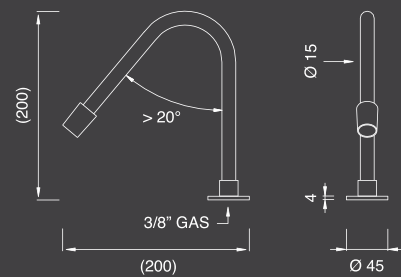

### SWI 05 + SWI 09W + SWI 08

Dual lever wall mounted mixer with Delrin® hand shower  
Mezclador bimando mural con teleducha en Delrin®  
843 Aprox.



FIX

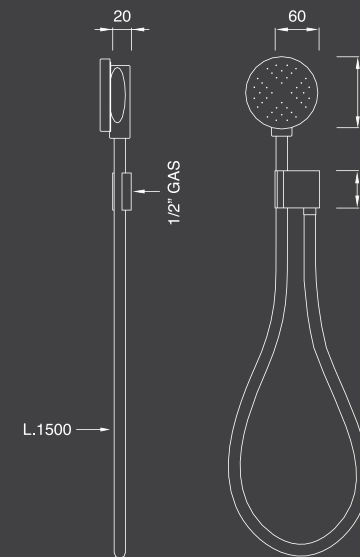



### SWI 05

Dual lever wall mounted mixer without frame to install on panel, with built-in part PWFS  
 Mezclador bimando mural sin embellecedor para montaje sobre panel, con cuerpo empotrado PWFS  
 1.187 Aprox



### SWI 04

Dual lever wall mounted mixer with frame, 1/2" gas connection  
 Mezclador bimando mural con embellecedor, conexiones de 1/2" gas  
 1.062 Aprox.

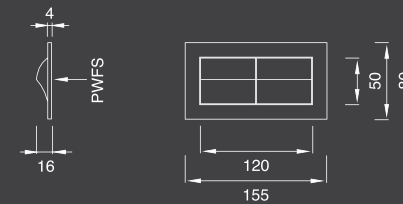



**2 SWI 04 + SWI 07G + FRE 31**

Square adjustable shower head L. 400 mm, with transparent silicone nozzles  
 Rociador cuadrado orientable L. 400 mm, con boquillas en silicona transparente  
 812 Aprox.

**SET**

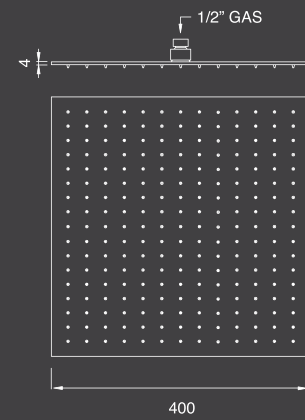

**AST 02**

Hydroprogressive mixer with adjustable and removable spout H. (260 mm)  
 Mezclador hidroprogresivo monomando con caño orientable y extraíble H. (260 mm)  
 981 Aprox.

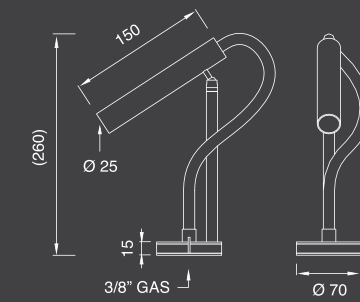

**AST 08**

Wall mounted hydroprogressive mixer with 1/2" gas connection  
 Mezclador hidroprogresivo mural con conexiones de 1/2" gas  
 250 Aprox

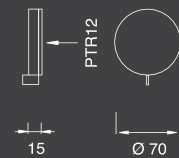

**AST 08 + AST 09W**

Wall mounted adjustable and removable spout P. (240 mm)  
 Caño mural orientable y extraíble P. (240 mm)  
 481 Aprox.

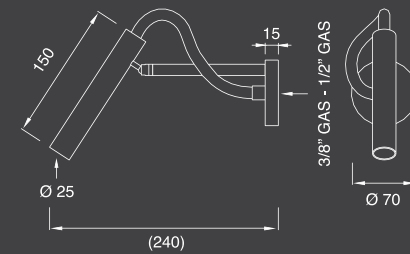





### AST 10W

Adjustable and removable spout for bathtub/shower P. (240 mm). Hose in coloured silicone rubber  
Caño de bañera/ducha orientable y extraíble P. (240 mm). Flexo en goma de silicona coloreada  
812 Aprox.



FIX

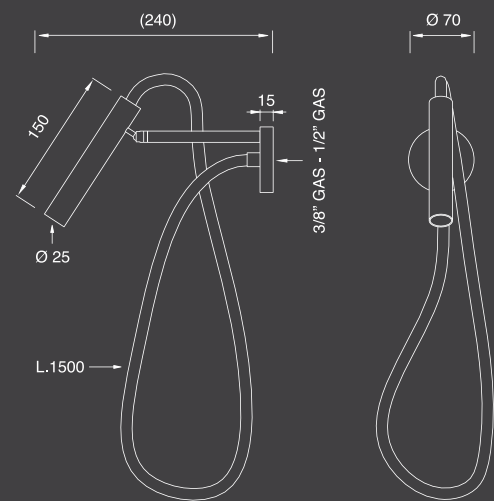

AST 08 + AST 10W

## 2 AST 08 + FLX 06 + AST 11W

Hand shower in coloured silicone rubber with bracket/water connection  
Teleducha en goma de silicona coloreada con soporte/toma de agua  
306 Aprox

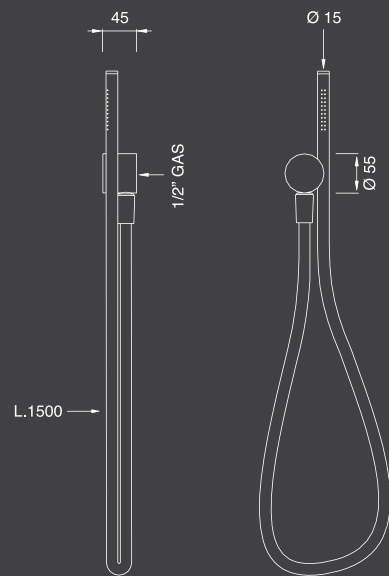

## AST 11W

Ceiling mounted shower head H. 620 mm  
Ducha de techo H. 620 mm  
718 Aprox

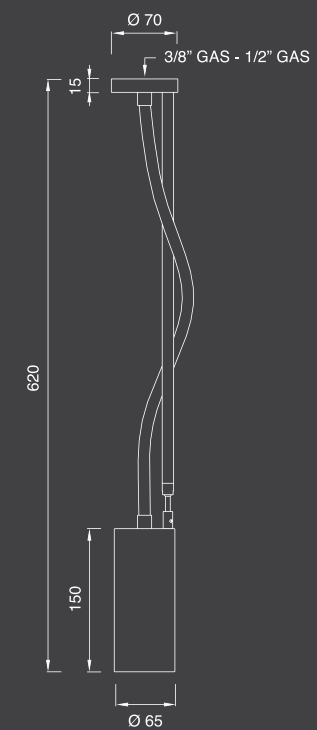



### GRA 04

Deck mounted hydroprogressive mixer with swivelling spout H. 230 mm  
 Mezclador hidroprogresivo monomando con caño giratorio H. 230 mm  
 637 Aprox.

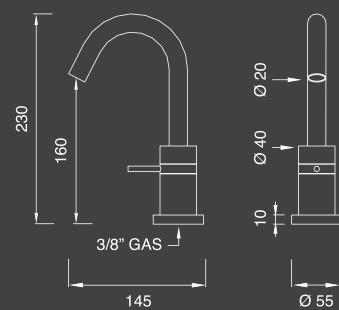

### GRA 01

Wall mounted hydroprogressive mixer with spout L. 170 mm  
 Mezclador hidroprogresivo mural con cáno L. 170 mm  
 606 Aprox.

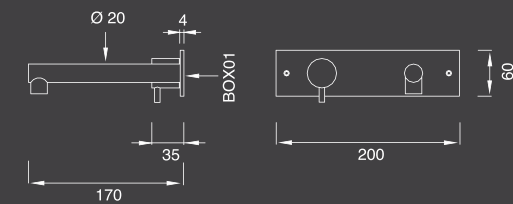



### GRA 18

Deck mounted hydroprogressive mixer with swivelling spout H. 385 mm  
 Mezclador hidroprogresivo monomando con caño giratorio H. 385 mm  
 850 Aprox

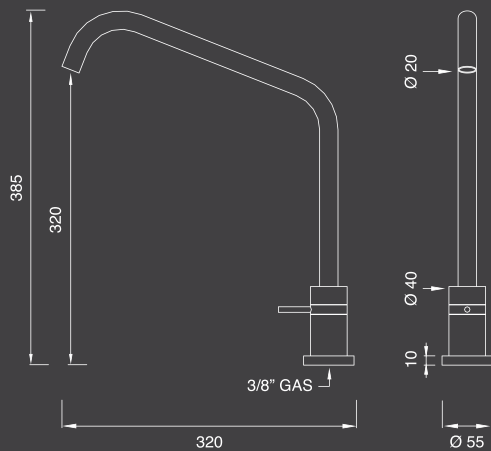

**GRA 12**  
 Freestanding hydroprogressive mixer for washbasin with swivelling spout H. 1150 mm  
 Mezclador hidroprogresivo a suelo para lavabo con caño giratorio H. 1150 mm  
 718 Aprox

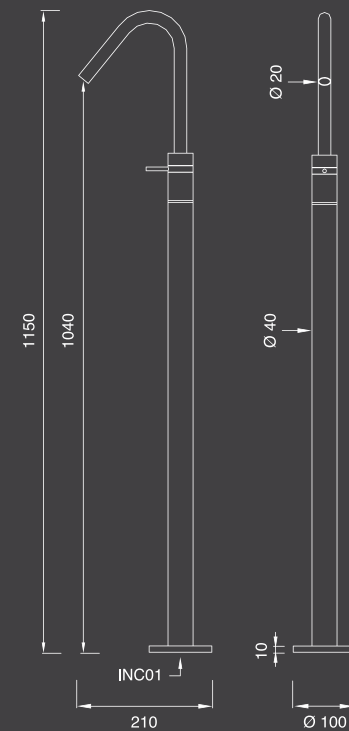



### GRA 11

Deck mounted hydroprogressive mixer with 3/8" gas connection  
 Mezclador hidroprogresivo de repisa con conexiones de 3/8" gas  
 337 Aprox.

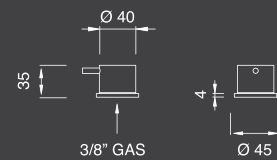

### FRE 06

Deck mounted swivelling spout H. 270 mm  
 Caño giratorio de repisa H. 270 mm  
 300 Aprox.

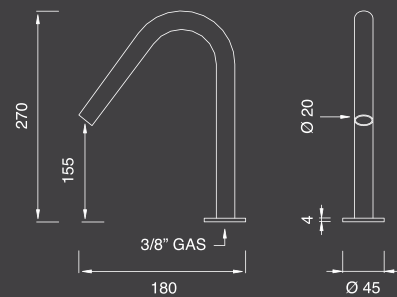

### GRA 19

Ceiling mounted hydroprogressive mixer for washbasin H. max. 1650 mm  
Mezclador hidroprogresivo de techo para lavabo H. max. 1650 mm  
1.225 Aprox

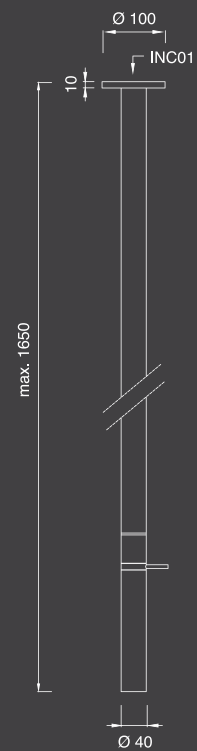

### GRA 13

Freestanding hydroprogressive mixer H. 975 mm for bathtub with swivelling spout  
Mezclador hidroprogresivo de suelo H. 975 mm para bañera con caño giratorio  
1.287 Aprox

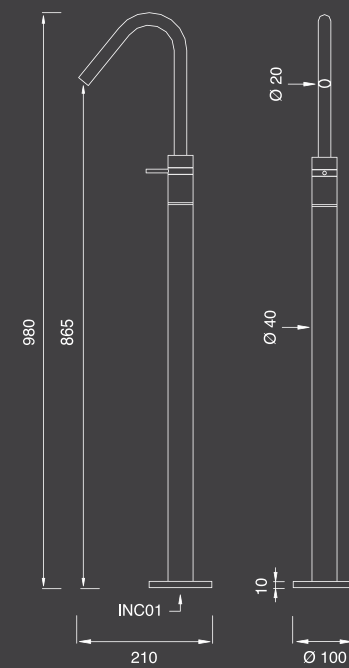



### GRA 08G + FRE 32 + BRA 03

Set of 2 hydroprogressive mixers for bath/shower with hand shower  
 Grupo 2 mezcladores hidroprogresivos para bañera/ducha con teleducha  
 1.106 Aprox.

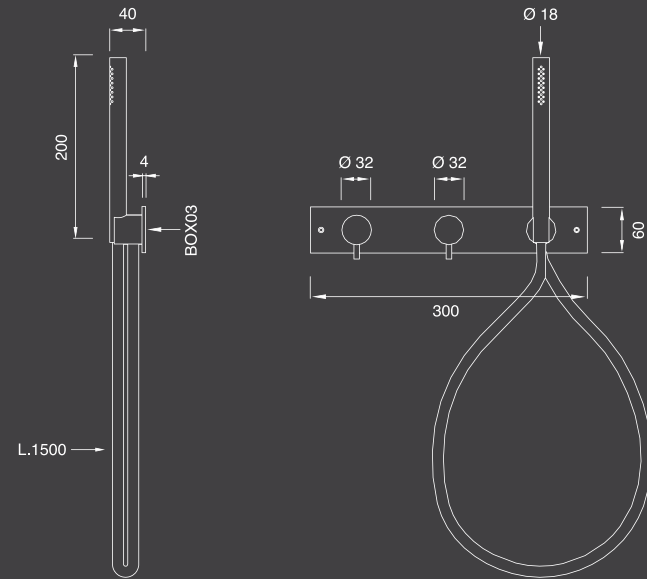

### GRA 07W + NEU 08 + MEN 02 +DOS 02

Hydroprogressive shower set H. 1200 mm with round adjustable shower head ø 200 mm and hand shower  
 Grupo de ducha H. 1200 mm con rociador redondo orientable ø 200 mm y teleducha  
 1.806 Aprox.

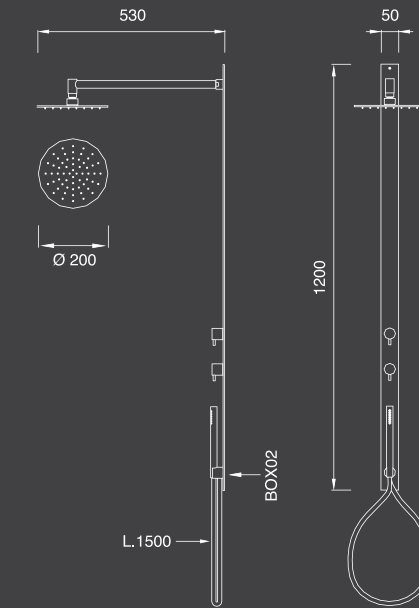





## GRA 16

Free-standing hydroprogressive mixer set H. 2210 mm with adjustable water saving shower head (5 lt/min), wall bracket and hand shower  
Columna hidroprogresiva para ducha H. 2210 mm con rociador orientable con ahorro de agua (5lt/min), soporte mural y teleducha  
2.775 Aprox

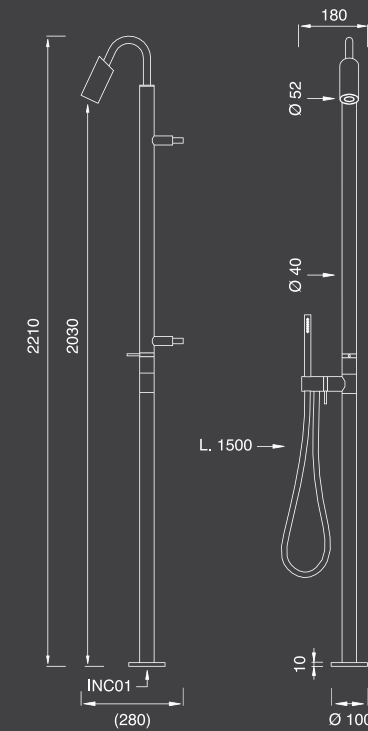

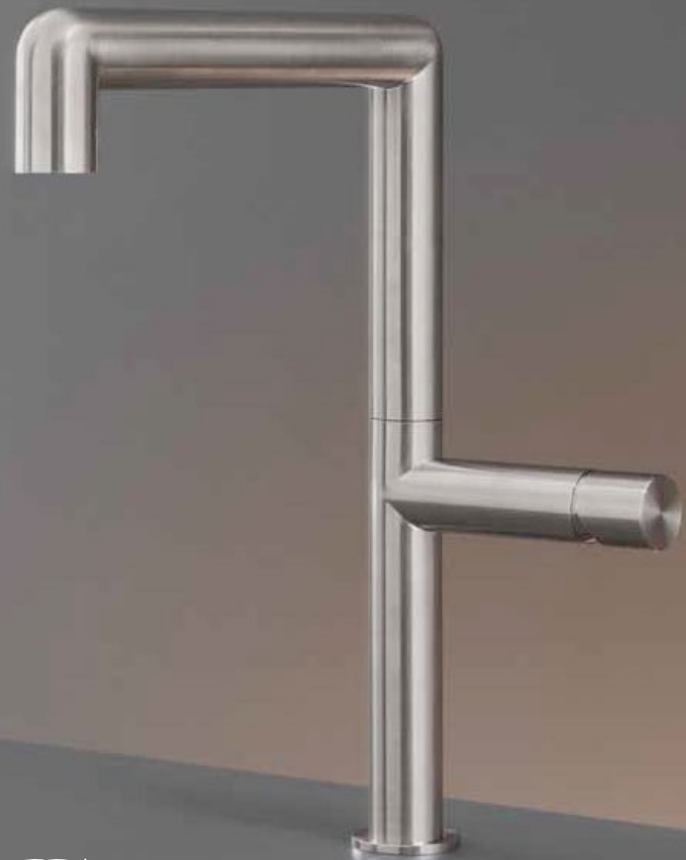

### CAR 01

Deck mounted mixer with swivelling spout H. 340 mm  
 Mezclador monomando con caño giratorio H. 340 mm  
 1.187 Aprox.

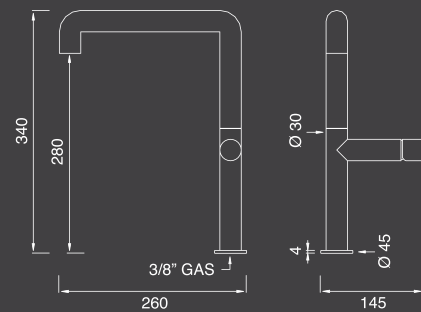

### CAR 04

Free-standing mixer for washbasin with swivelling spout H. 1100 mm  
 Mezclador de suelo para lavabo con caño giratorio H. 1100 mm  
 1.445 Aprox.

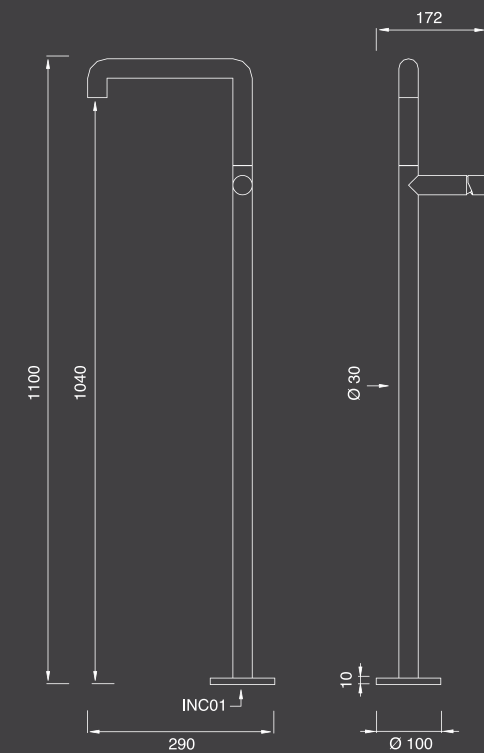

### CAR 24

Three-hole mixer with swivelling spout H. 280 mm  
Grifería con 3 orificios con caño giratorio H. 280 mm  
1.262 Aprox

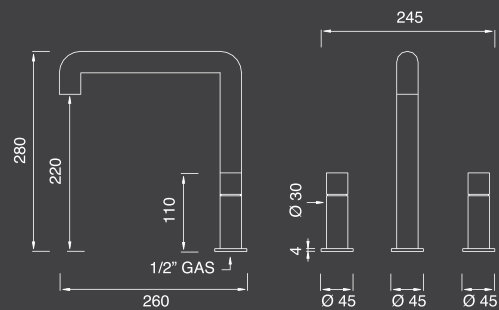

### CAR 09

Wall mounted mixer with spout L. max. 245 mm  
Mezclador mural con caño L. max. 245 mm  
550 Aprox

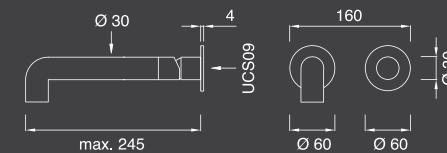



### CAR 80

Deck mounted mixer with adjustable spout H. 115 mm  
 Mezclador monomando con caño orientable H. 115 mm  
 387 Aprox.

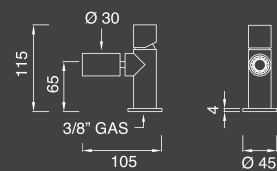

### CAR 50W + FRE 41

Set of 2 mixers for bath/shower with hand shower  
 Grupo 2 mezcladores mural para bañera/ducha con teleducha  
 587 Aprox.

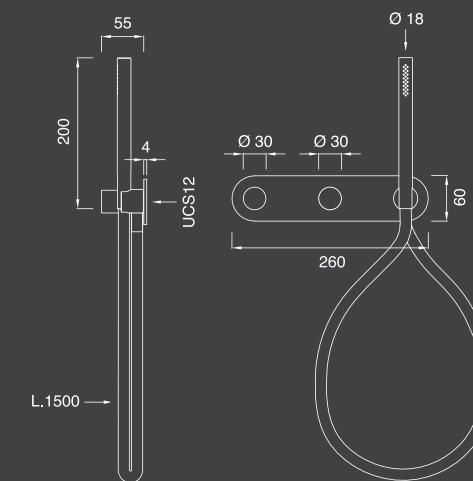

**CAR 61 + FRE 17 + FRE 13 + GIO 02 +GIO 03**

Hyperbolic shower head P. 245 mm  
Ducha hiperbólica P. 245 mm  
1.225 Aprox

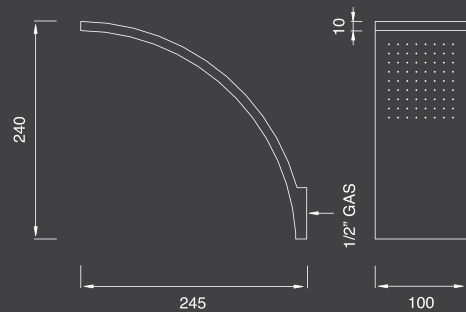

**2 CAR 15 + FRE 17 + FRE 34**

Hand shower with bracket/water connection. Hose in stainless steel  
Teleducha con soporte y toma de agua. Flexo en acero inoxidable  
387 Aprox

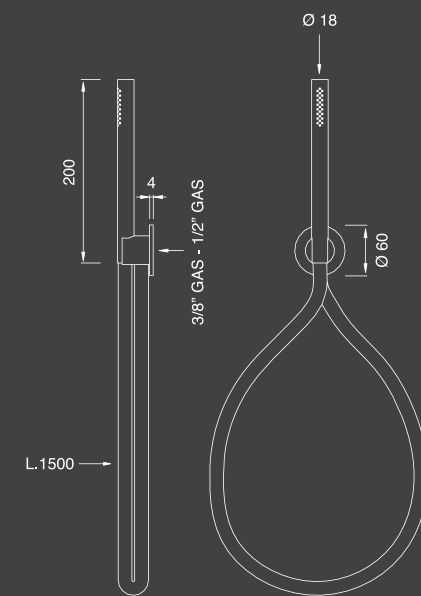



**FRE 34**

Rain jet shower head P. 180 mm, with transparent silicone nozzles  
 Rociador chorro lluvia P. 180 mm, con boquillas en silicona transparente  
 1.100 Aprox



FIX

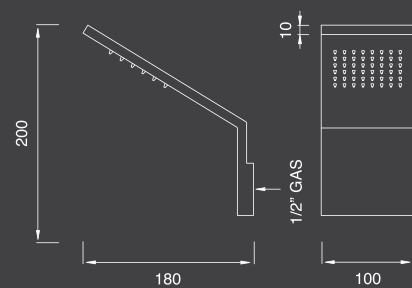

**CAR 19 + CAR 54**

Free-standing spout for bathtub H. 810 mm  
 Caño bañera de suelo H. 810 mm  
 887 Aprox.

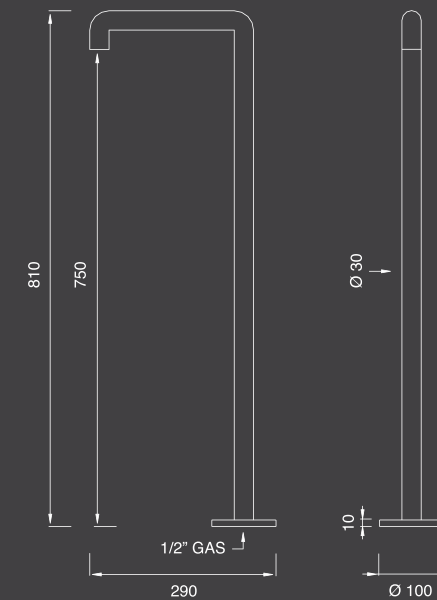

### FRE 56 + INV 80

Deck mounted swivelling spout H. 360 mm  
Caño giratorio de repisa H. 360 mm  
400 Aprox

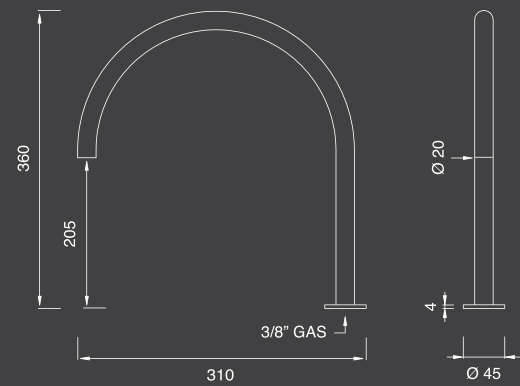

### INV 80

Wall mounted single lever mixer with 1/2" gas connection  
Mezclador monomando mural con conexiones de 1/2"  
181 Aprox

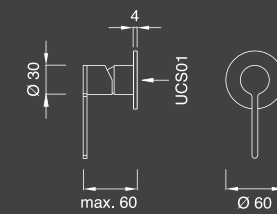





### INV 11

Wall mounted mixer with spout L. max. 185 mm  
Mezclador mural con caño L. max. 185 mm  
306 Aprox

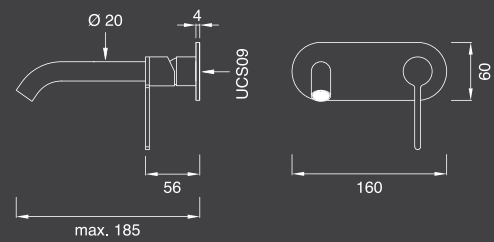

### INV 01

Deck mounted mixer H. 155 mm  
Mezclador monomando H. 155 mm  
450 Aprox.

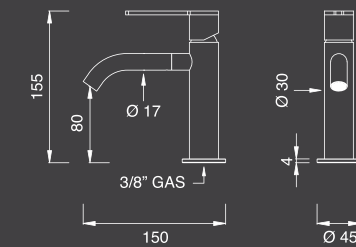

### INV 43

Three-hole mixer with swivelling spout H. 245 mm  
Grifería con 3 orificios con caño giratorio H- 245 mm  
1.062 Aprox

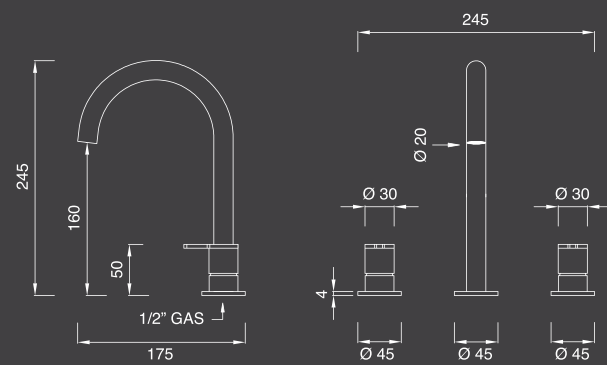

### INV 53W

Set of 2 mixers for bath/shower with hand shower  
Grupo 2 mezcladores mural para bañera/ducha con teleducha  
781 Aprox

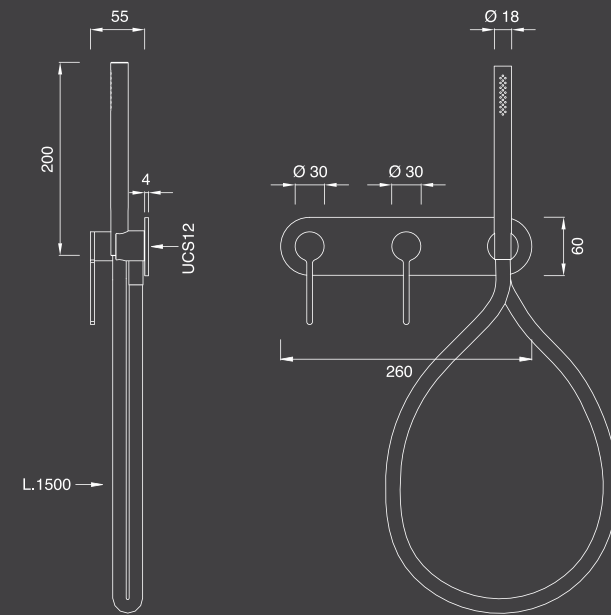

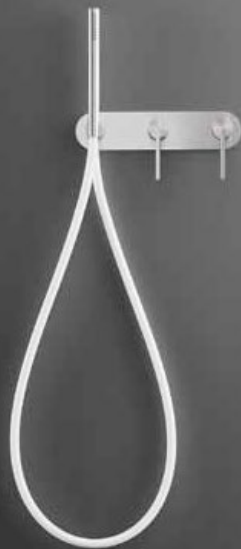

### INV 53 + FRE 12 + BRA 07

Round adjustable shower head  $\varnothing$  200 mm, with transparent silicone nozzles  
Rociador redondo orientable  $\varnothing$  200 mm, con boquillas en silicona transparente  
350 Aprox

SET

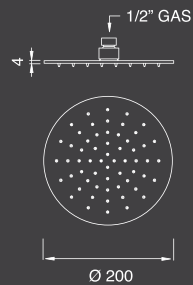

### MIL 16

Deck mounted mixer H. 155 mm  
Mezclador monomando H. 155 mm  
425 Aprox.

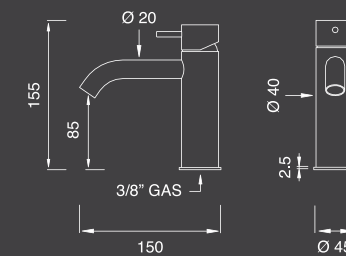

### MIL 17

Deck mounted mixer for countertop basin H. 315 mm  
Mezclador monomando para lavabo de apoyo H. 315 mm  
475 Aprox

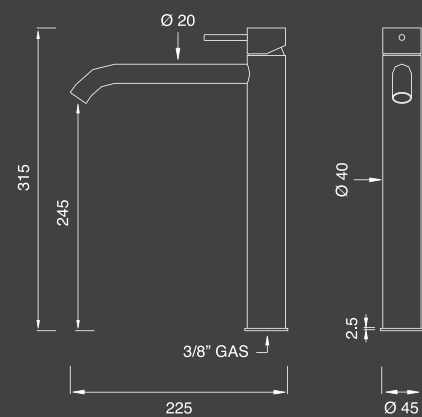

### MIL 78

Three-hole mixer with swivelling spout H. 190 mm  
Grifería con 3 orificios con caño giratorio H. 190 mm  
925 Aprox

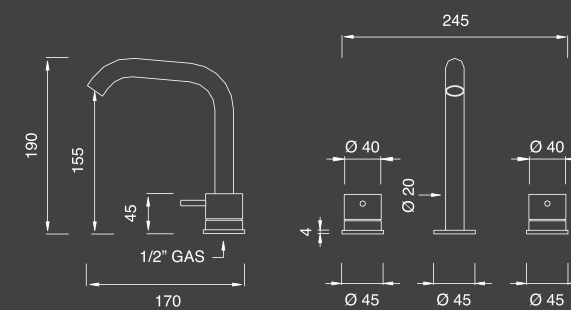



### MIL 35

Wall mounted mixer with spout L. max. 185 mm  
Mezclador mural con caño L. max. 185 mm  
387 Aprox

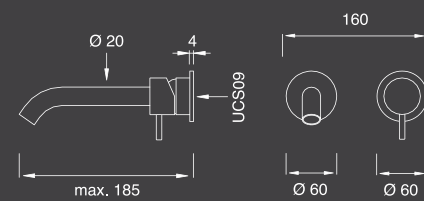



### MIL 04

Wall mounted mixer with spout L. max. 185 mm  
 Mezclador mural con caño L. max. 185 mm  
 375 Aprox

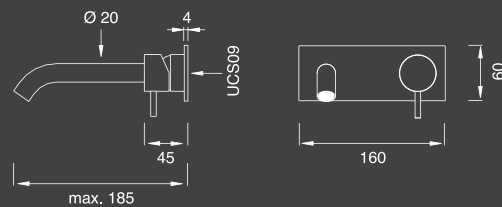

### MIL 46 + IRS 01

Wall mounted spout L. max. 185 mm  
 Caño mural L. max. 185 mm  
 206 Aprox

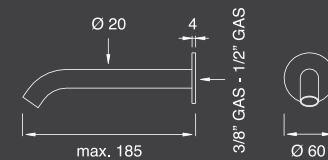



### MIL 46 + IRS 03

Wall mounted On/off infrared sensor  
 Sensor de infrarrojos mural con función de encendido-apagado  
 743 Aprox



### MIL 100 + MIL 90W + FRE 12 + BRA 03

Thermostatic mixer set with 2 shut-off valves  
 Grupo mezclador ducha termostático con 2 llaves de paso  
 487 Aprox.

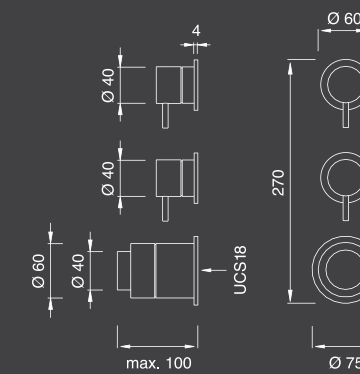



### MIL 81 + FLX 05W

Kneipp jet with water connection. Hose in coloured silicone rubber or stainless steel  
Chorro Kneipp con toma de agua. Flexo en goma de silicona coloreada  
o acero inoxidable  
275 Aprox

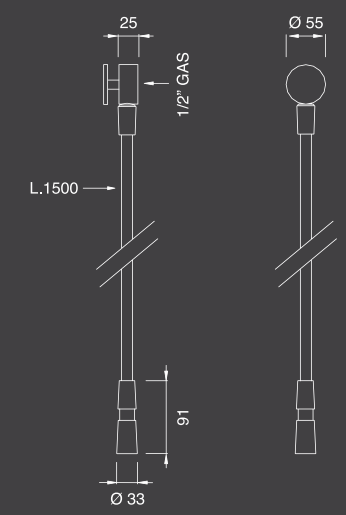



**MIL 95W + DOS 02 + 2 MIL 91**

Wall mounted external mixer set, usable as shelf, with hand shower  
 Grupo mezclador exterior mural, utilizable como repisa, con teleducha  
 875 Aprox

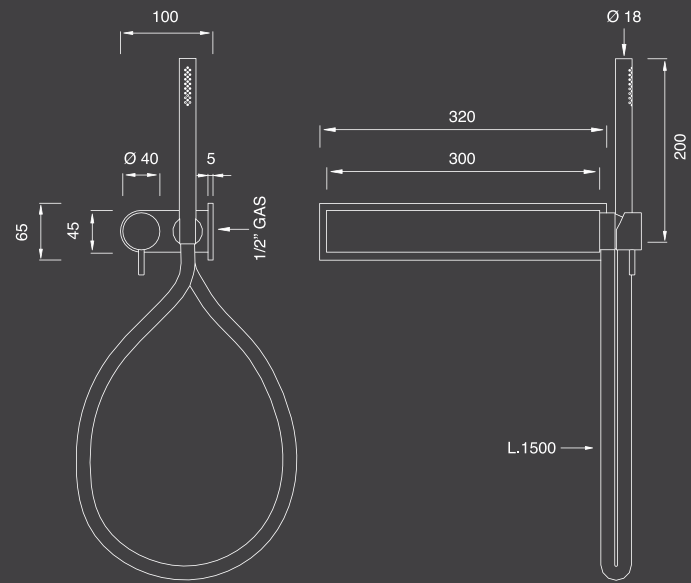

**FRE 58 + MIL 104 + MIL 90W + MIL 02**

Free-standing spout for bathtub H. 750 mm  
 Caño bañera a suelo H. 750 mm  
 618 Aprox.

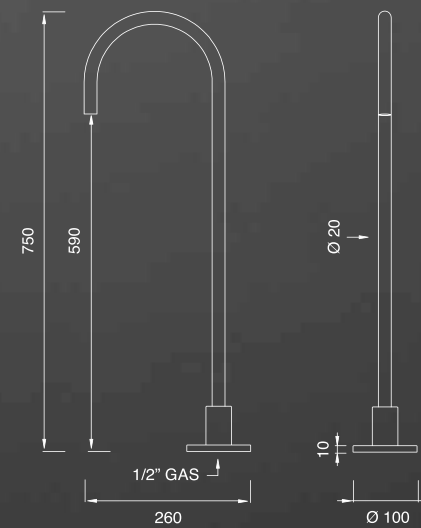

### MIL 28

Rim mounted thermostatic mixer set with spout, shut-off diverter and hand shower  
Grupo mezclador termostático para borde bañera con caño, inversor y teleducha  
1.550 Aprox

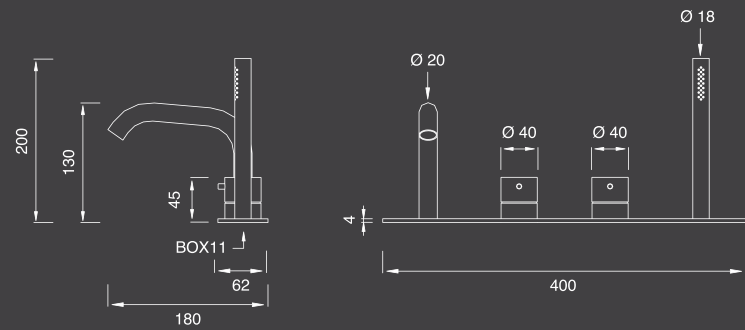

126



### MIL 19G

Free-standing mixer for bathtub with hand shower H. 850 mm  
Mezclador a suelo para bañera con teleducha H. 850 mm  
1.400 Aprox

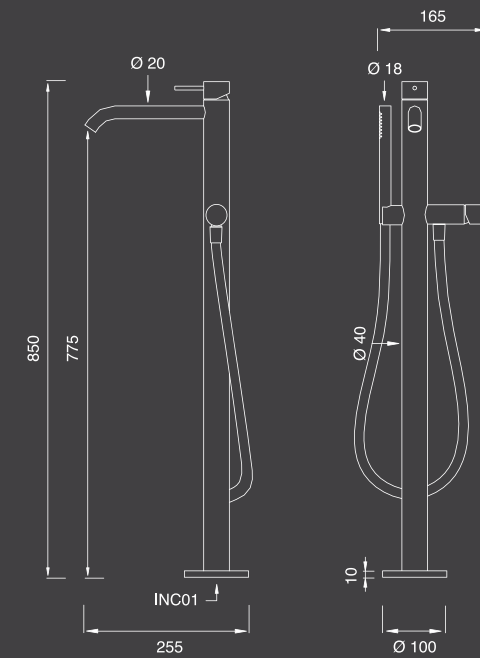

127

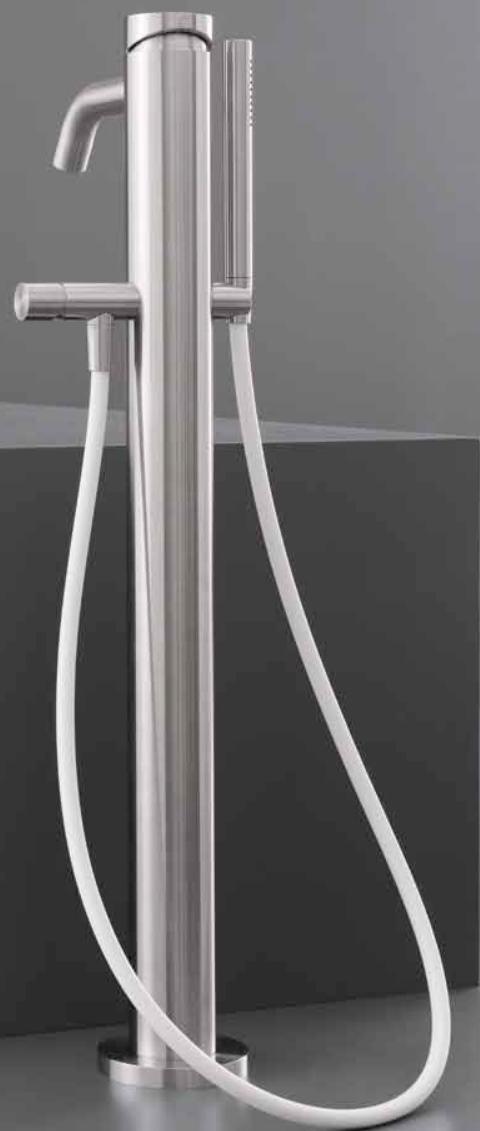

### MIL 99

High water flow free-standing mixer for bathtub with hand shower H.840 mm  
 Mezclador de alta capacidad a suelo para bañera con teleducha H. 840 mm  
 3.050 Aprox

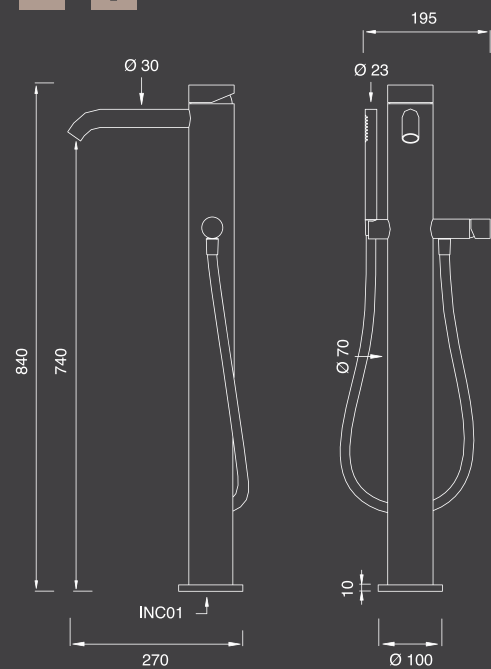

### MEN 03 + MEN 06 + STE 04 + STE 08 + STE 01 + PLA 02 + POS 01 + STE 05

Plate for dual flush Geberit cistern with flush buttons  
 Pulsador para cisterna a 2 flujos Geberit con botones alineado  
 562 Aprox.

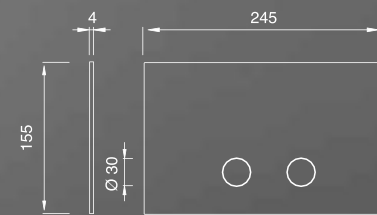



### STE 01

Pair of hooks  
Par de colgadores  
131 Aprox

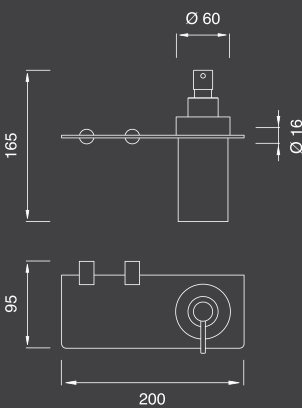
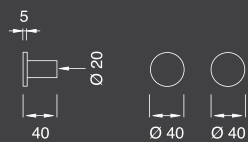

### MEN 06

Shelf with Delrin® dispenser  
Repisa con dosificador en Delrin®  
443 Aprox



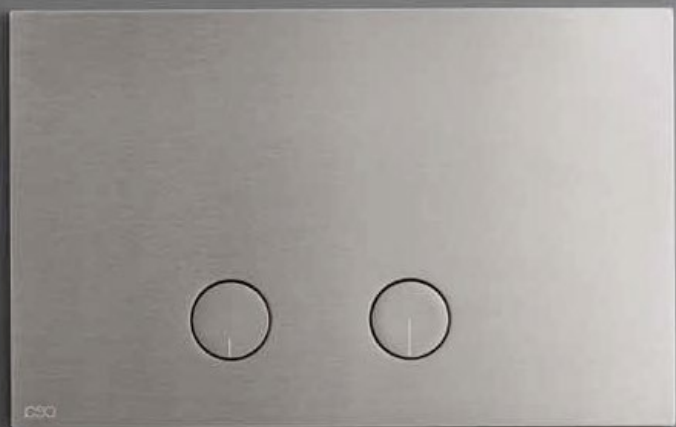

**PLA 02**

Plate for dual flush Geberit cistern with flush buttons  
 Pulsador para cisterna a 2 flujos Geberit con botones alineado  
 537 Aprox.

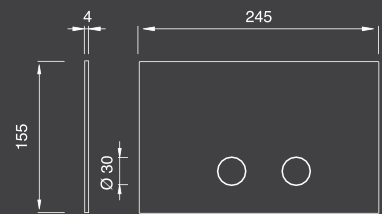

**PLA 05**

Plate for dual flush Geberit cistern with rollaway water jet toilet cleaner  
 and flush buttons  
 Pulsador para cisterna a 2 flujos Geberit con hidroescobilla para WC,  
 botones alineado  
 943 Aprox.

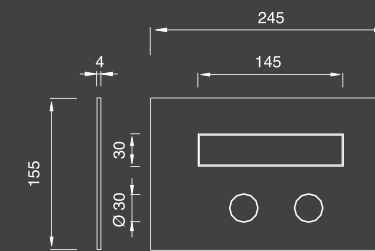

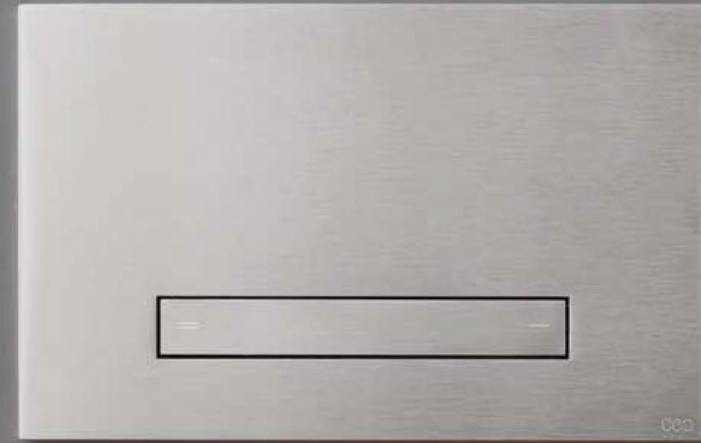

**PLA 07**

Plate for dual flush Geberit cistern with flush tilting button  
 Pulsador para cisterna a 2 flujos Geberit con botón basculante alineado  
 600 Aprox

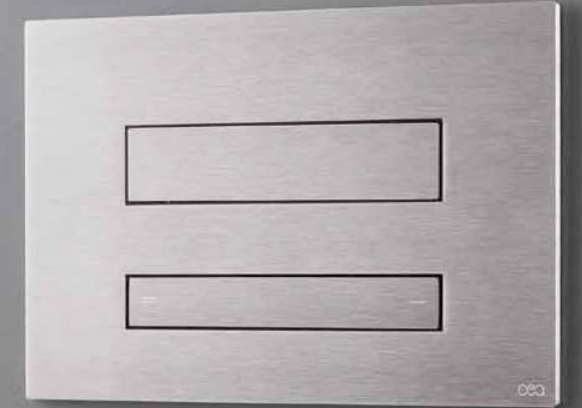
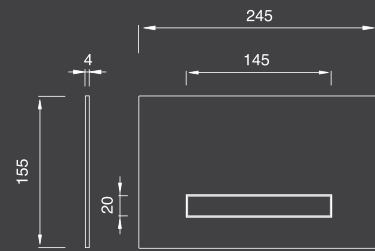

**PLA 06**

Plate for dual flush Geberit cistern with rollaway water jet toilet cleaner  
 and flush tilting button  
 Pulsador para cisterna a 2 flujos Geberit con hidroescobilla para WC  
 y botón en basculante alineado  
 1.012 Aprox

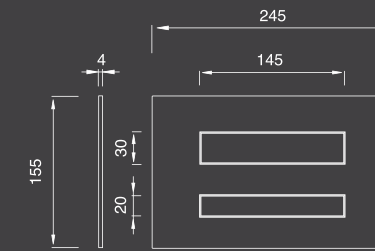



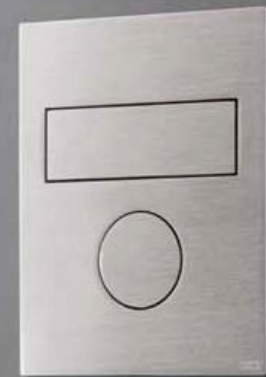

### PLA 11

Plate for progressive flow Grohe Dal cistern with flush button and rollaway water jet toilet cleaner  
Pulsador para cisterna a flujo progresivo Grohe Dal con botón alineado y hidroescobilla para WC  
968 Aprox.

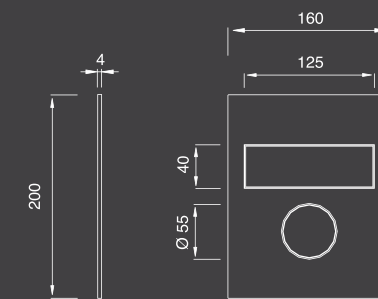

**PUL 06**

Pair of buttons for dual flush Geberit cistern installed on panel accessible for inspection.  
 Cistern is not necessary  
 Pareja de botones para cisterna a 2 flujos Geberit para panel inspeccionable. No se necesita cisterna  
 337 Aprox

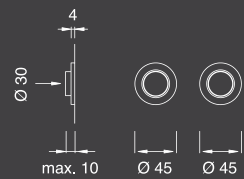

**PLA 08**

Rollaway water jet toilet cleaner with pressure opening hatch  
 Hidroescobilla para WC con apertura a presión  
 693 Aprox

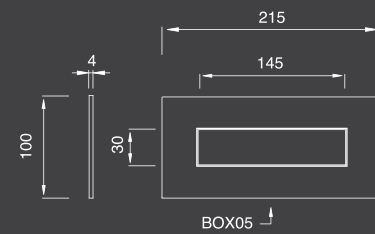



### PLA 09

Rollaway water jet toilet cleaner with pressure opening hatch and toilet paper holder  
 Hidroescobilla para WC con apertura a presión, portarollo integrado  
 906 Aprox.

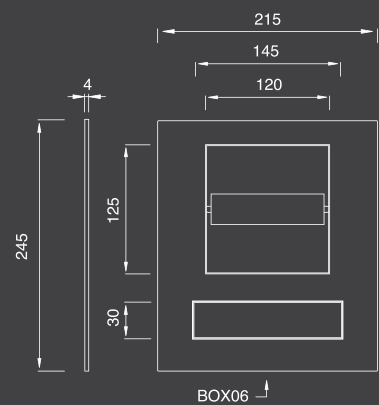

BOX06

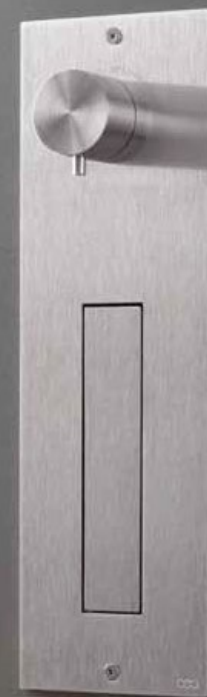

### FRE 84

Built-in bidet spray with thermostatic mixer  
 Hidroescobilla empotrada para higiene personal con mezclador termostático  
 1.200 Aprox.

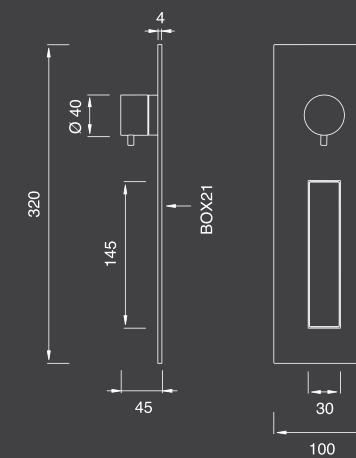

BOX21





### FRE 80

Water jet toilet cleaner with safety valve, wall bracket and water connection  
 Hidroescobilla para WC con válvula de seguridad, soporte y toma de agua  
 506 Aprox.



FIX

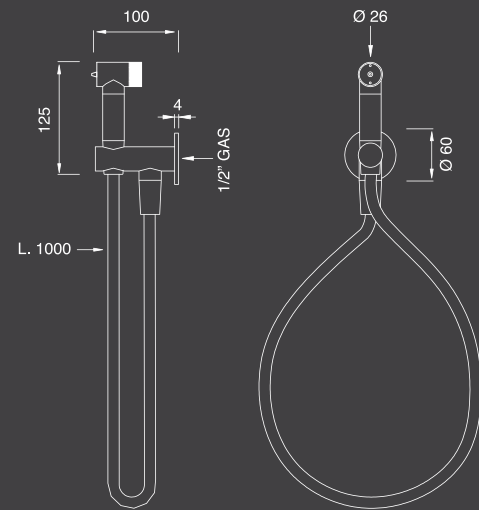

### NEU 83

Toilet roll holder with bidet spray, wall bracket and water connection - NEUTRA line  
 Portarollo con hidroescobilla para higiene personal, soporte y toma de agua - Línea  
 NEUTRA  
 593 Aprox.



FIX

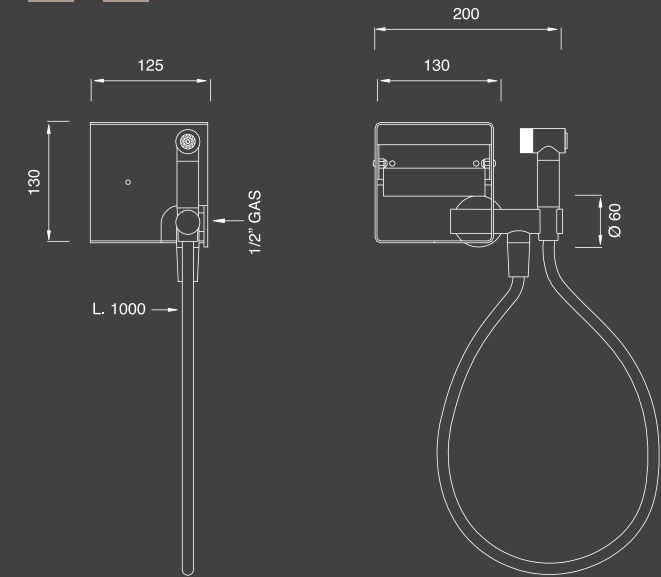

### FRE 44

Toilet roll holder with water jet toilet cleaner, safety valve, wall bracket and safety valve - STEM Line  
Portarollo con hidroescobilla para WC, válvula de seguridad, soporte y toma de agua - Línea STEM  
593 Aprox.

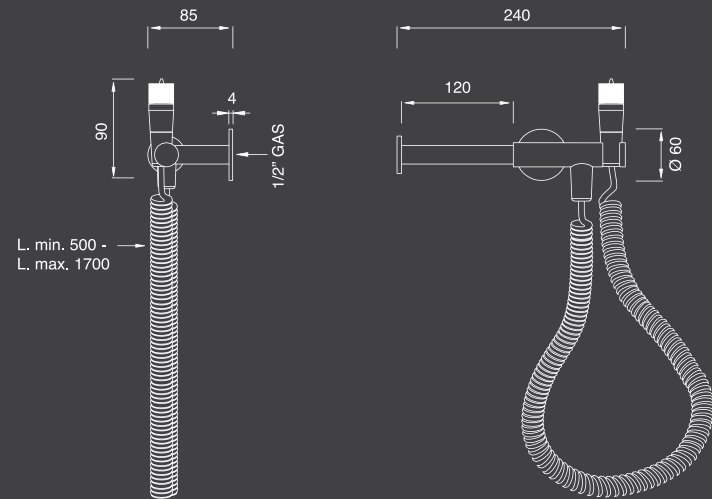

GO+ studio is aimed at professionals as engineers, architects or developers, and individuals in the construction industry, home improvements and interior design. With products from over 500 national and international manufacturers, we supply the finest: Porcelain, ceramic, natural stone and hardwood tiles. Paper and textile wall coverings and light fixtures. Indoor / outdoor furniture, taps and sanitary ware.







[www.goplus.es](http://www.goplus.es) +34 971 338 565 [info@goplus.es](mailto:info@goplus.es) · c/ Llauradors n1, nave 3. Poligono Industrial Monte Cristo, San Rafael, Ibiza. Islas Baleares 07816

